

Reservado el derecho a modificar el contenido de la entrega.

Änderungen des Lieferumfangs vorbehalten.

Equipment supplied is subject to alteration.

Sous réserve de modification du volume de livraison.

Si riserva il diritto di apportare modifiche all'oggetto della consegna.

Reservado o direito de modificar o conteúdo da entrega.

Τηρείται το δικαίωμα αλλαγών του πλαισίου παράδοσης.

Wijzigingen omtrent tijdstip van levering voorbehouden.

Změny v rozsahu dodávky vyhrazeny.

Ibiza 2008 ⇒

- GB** Required Tools
- D** Erforderliche Werkzeuge
- E** Herramientas necesarias
- F** Outils indispensables
- I** Strumenti necessari
- P** Ferramentas necessárias:
- GR** Απαραίτητα εργαλεία
- NL** Benodigd gereedschap
- CZ** Potřebné nářadí

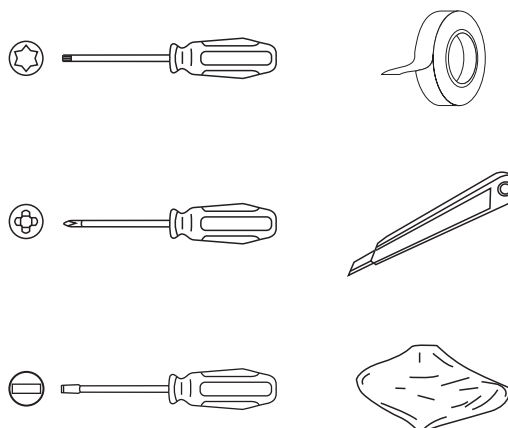

- GB** If your vehicle is NOT equipped with fog lamps (pictures 6 / 8 / 9 / 10 / 14 / 26 / 31), please use the fog lamp blank **parts K and L**.
- D** Sollte Ihr Fahrzeug NICHT mit Nebelscheinwerfer ausgestattet sein (Darstellung 6 / 8 / 9 / 10 / 14 / 26 / 31), so verbauen Sie bitte die Nebelscheinwerfer-Attrappe **Teil K und L**.
- E** Si el vehículo NO es equipado con faros antiniebla (ilustración 6 / 8 / 9 / 10 / 14 / 26 / 31), montar la imitación faros antiniebla **piezas K y L**.
- F** Si votre véhicule n'est PAS équipé d'un phare anti-brouillard (Version 6 / 8 / 9 / 10 / 14 / 26 / 31), alors obstruez les pièces de fixation **K et L** du phare anti-brouillard.
- I** Se il vostro veicolo NON è dotato di fari fendinebbia (figure 6 / 8 / 9 / 10 / 14 / 26 / 31), montare gli appositi tappi, pezzi **K e L**.
- P** Se o seu veículo não estiver equipado com faróis de nevoeiro (figuras 6 / 8 / 9 / 10 / 14 / 26 / 31), monte as partes **K e L** da maquete dos faróis de nevoeiro
- GR** Αν το όχημά σας ΔΕΝ διαθέτει προβολείς ομίχλης (απεικόνιση 6 / 8 / 9 / 10 / 14 / 26 / 31), Αφαιρέστε το κάλυμμα μέρος **K και L** για τους προβολείς ομίχλης.
- NL** Mocht uw auto NIET met mistlampen uitgerust zijn (afbeelding 6 / 8 / 9 / 10 / 14 / 26 / 31), monteer dan de mistlamp-atrappe deel **K en L**.
- CZ** Pokud NENÍ Vaše vozidlo vybaveno mlhovkami (obrázek 6 / 8 / 9 / 10 / 14 / 26 / 31), tak namontujte prosím atrapu mlhovek díl **K a L**.

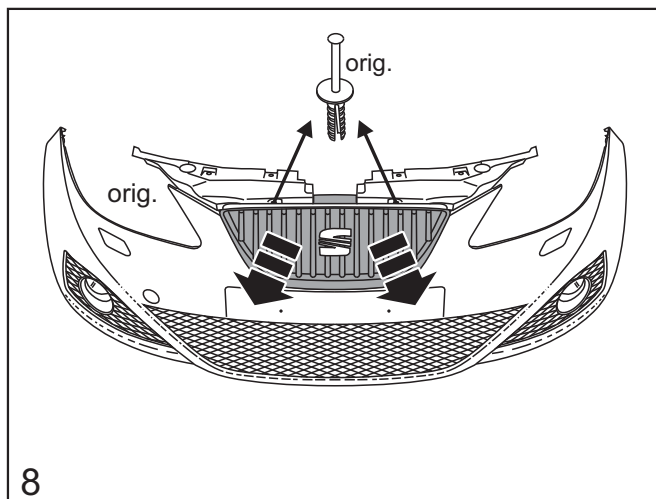
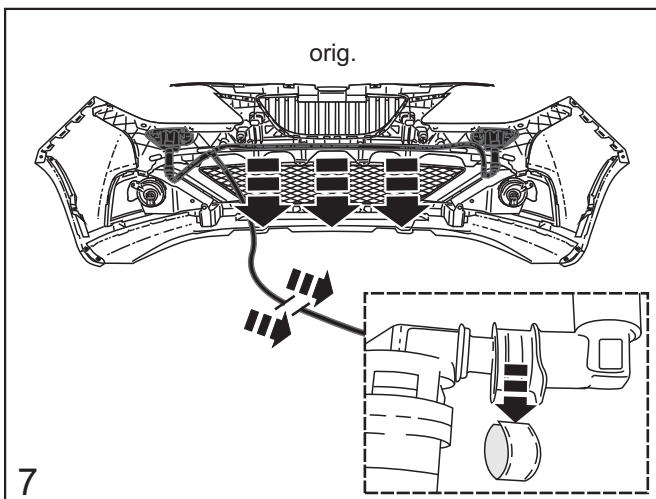
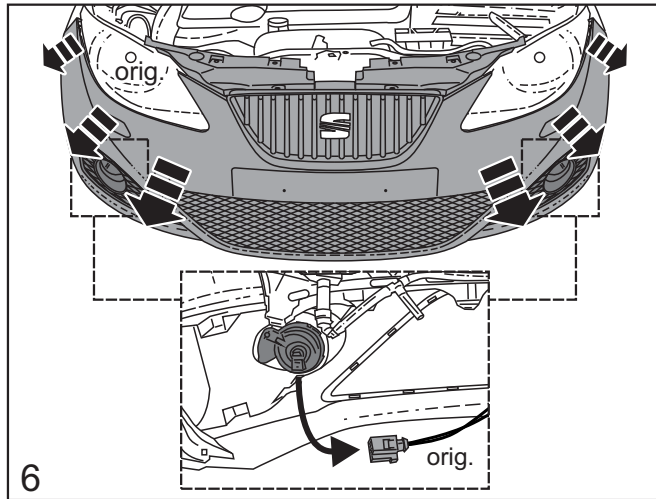
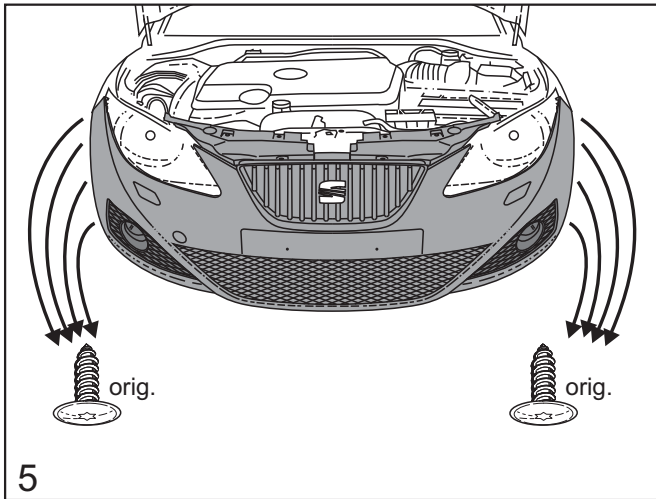
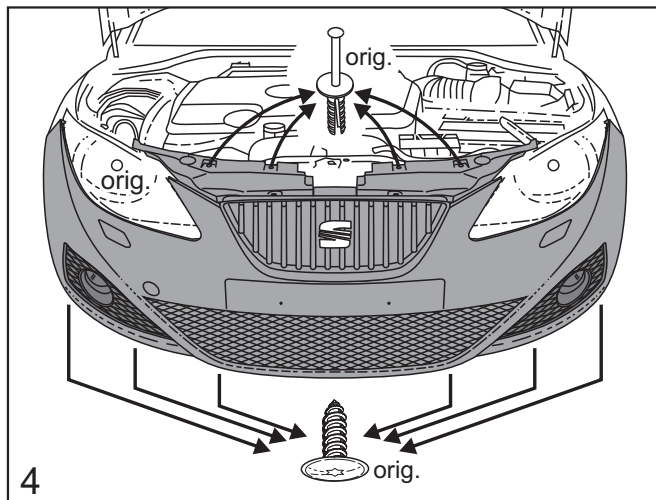
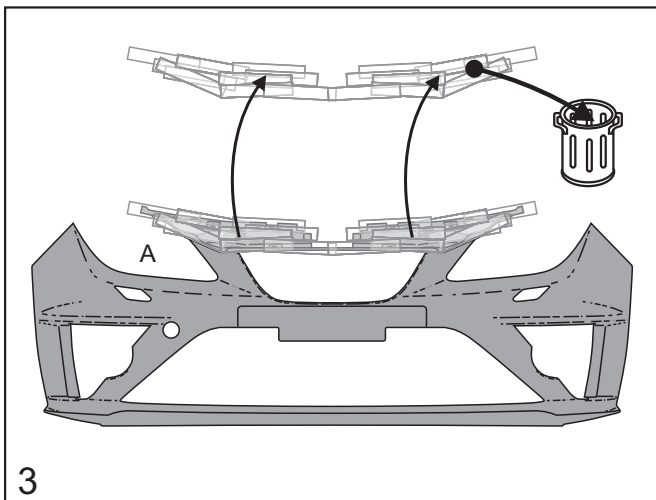
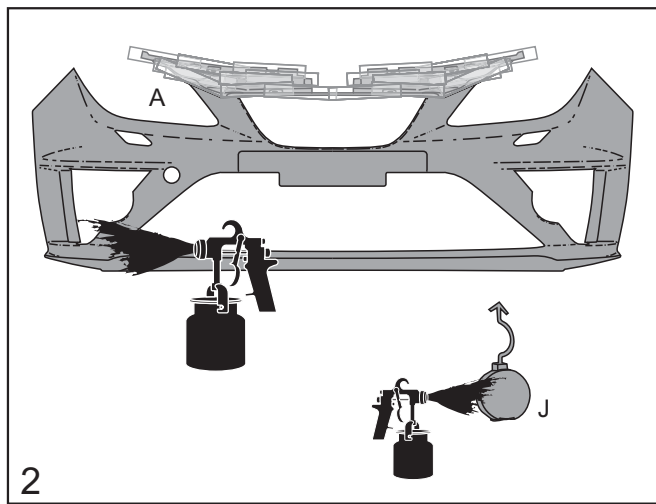
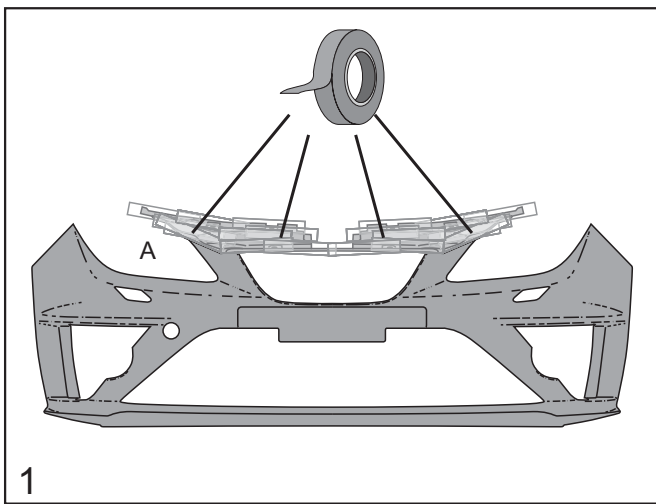

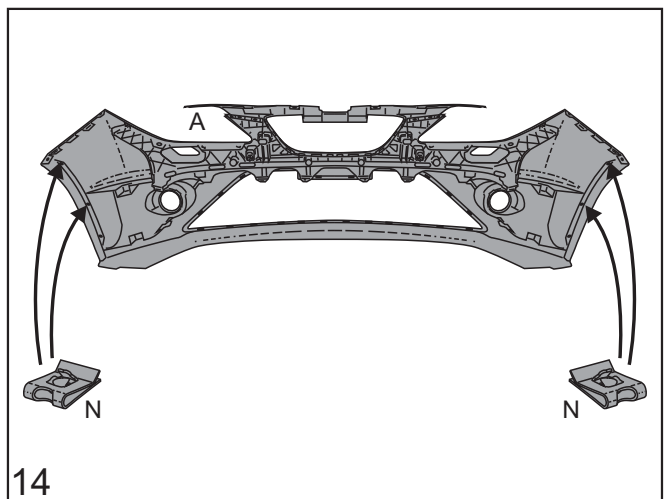
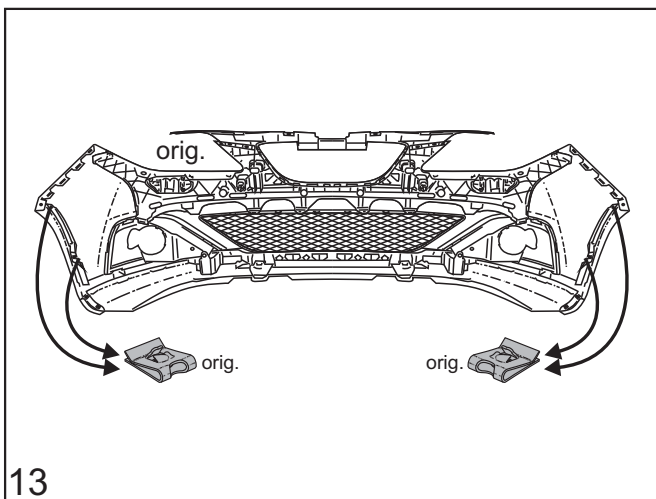
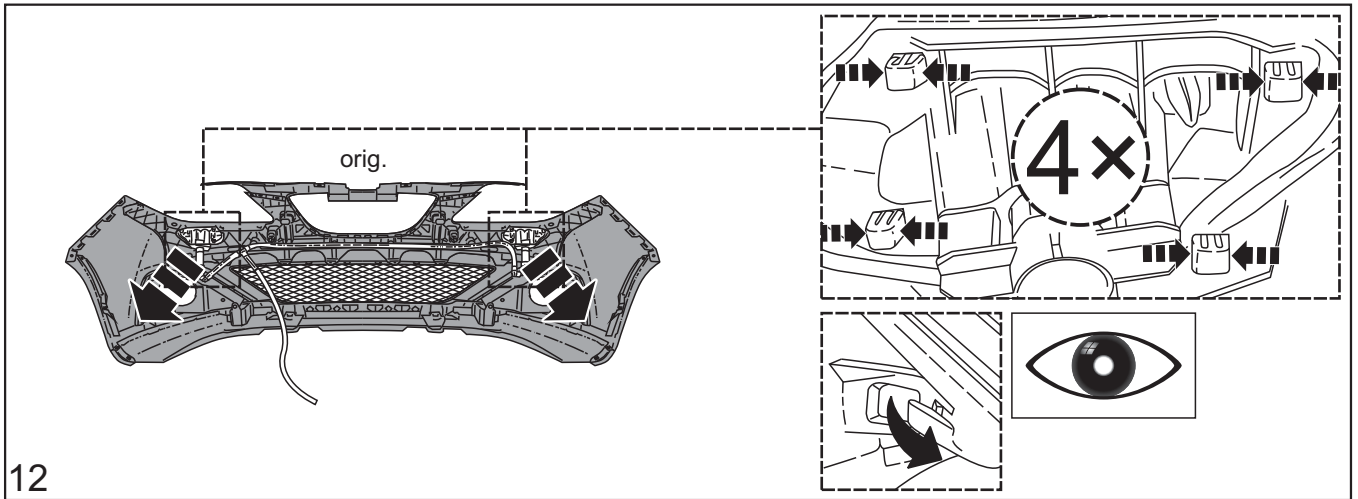
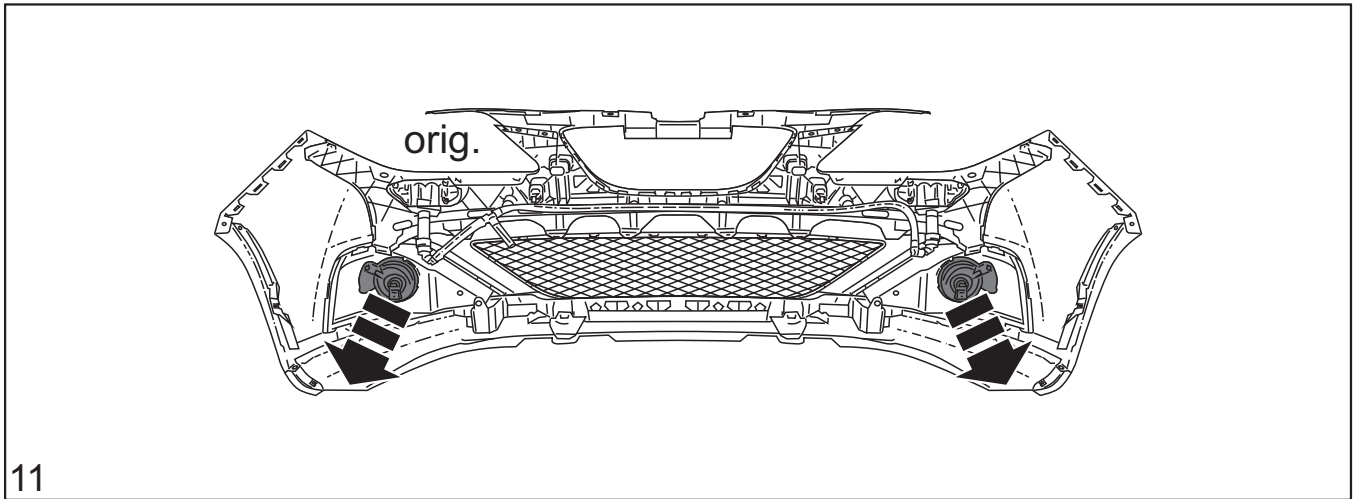
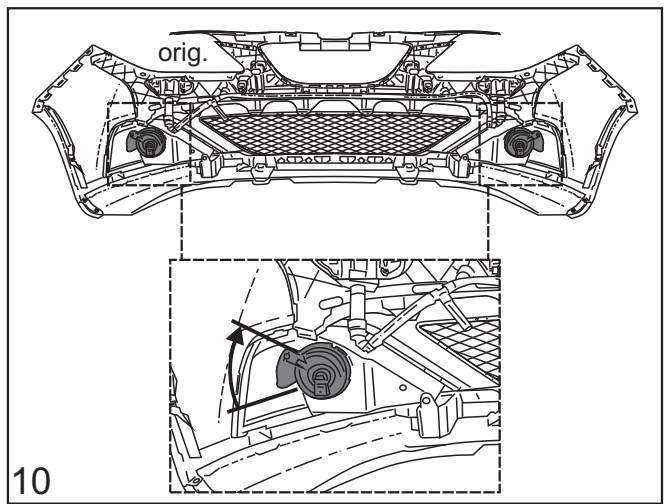
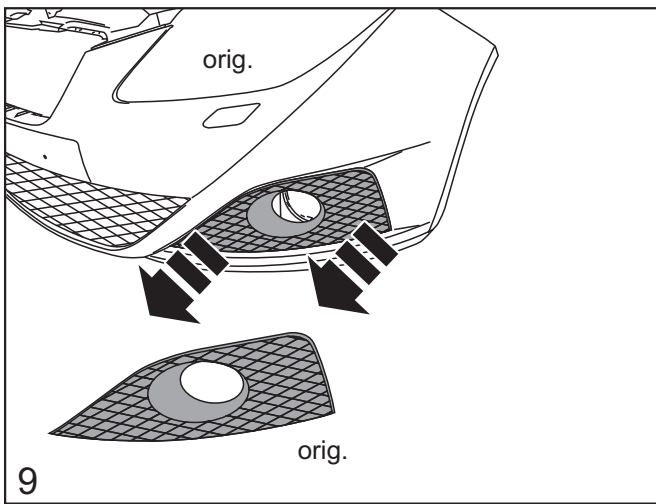

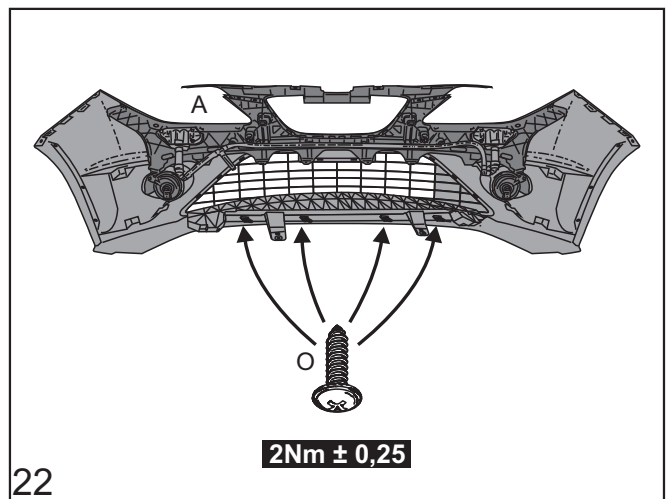
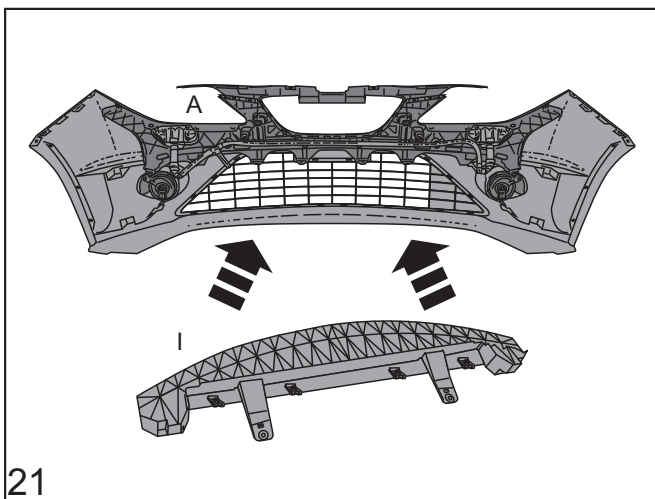
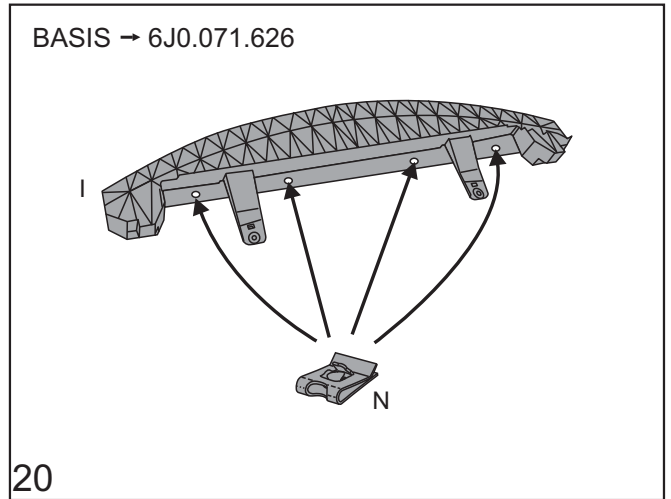
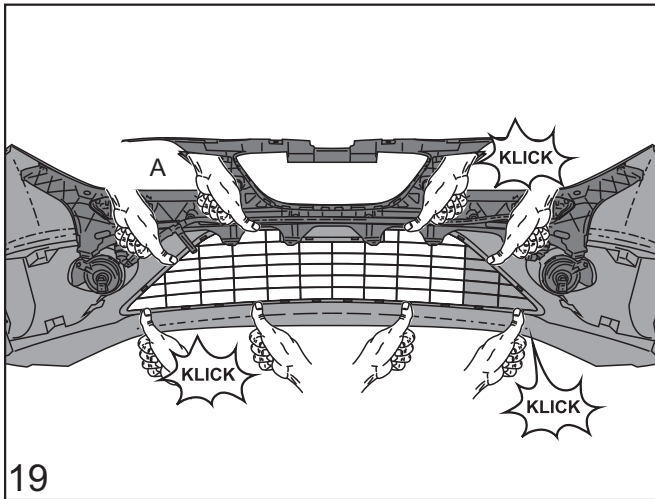
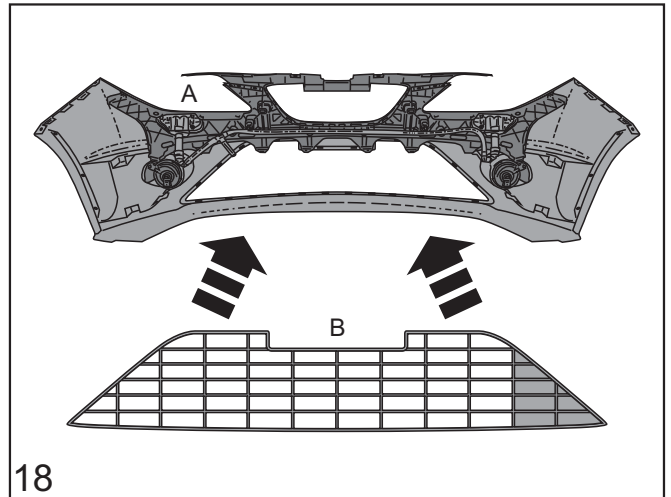
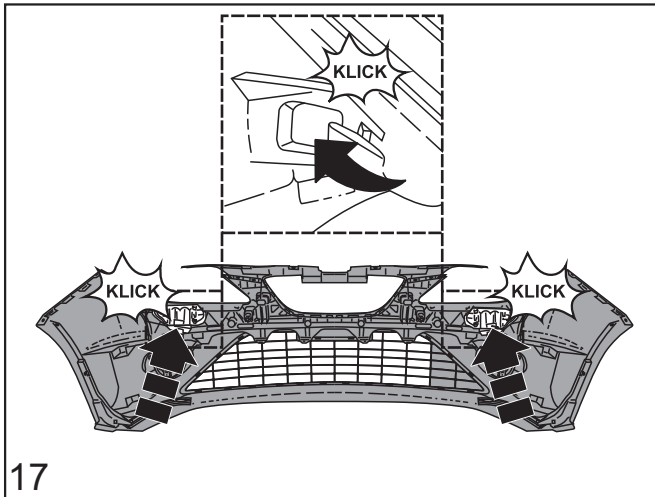
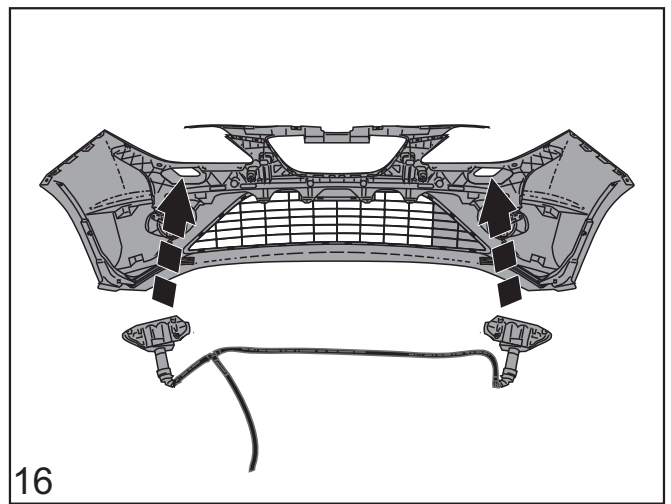
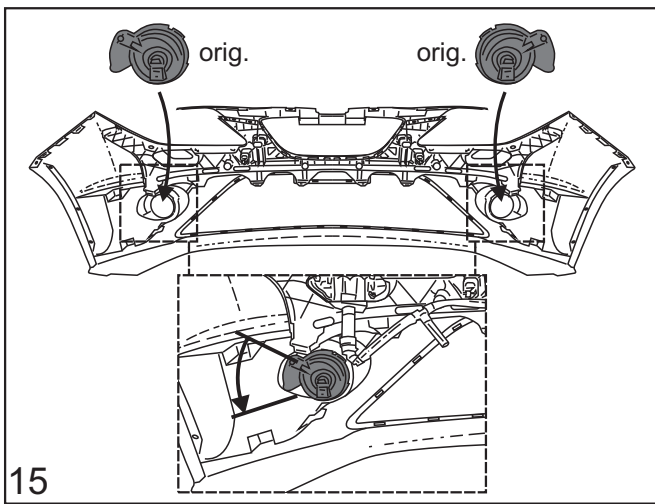

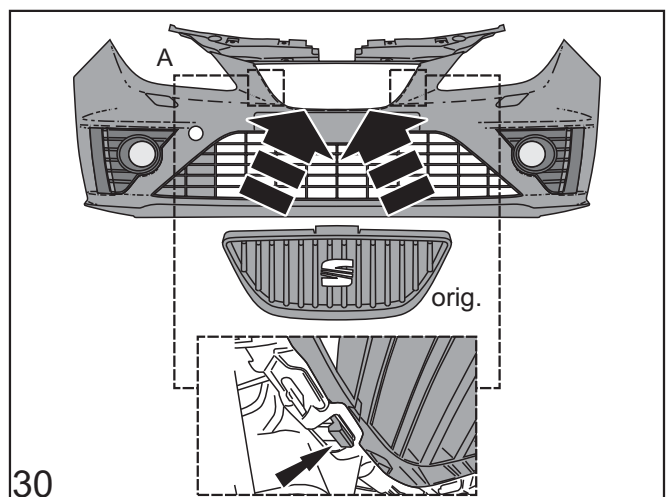
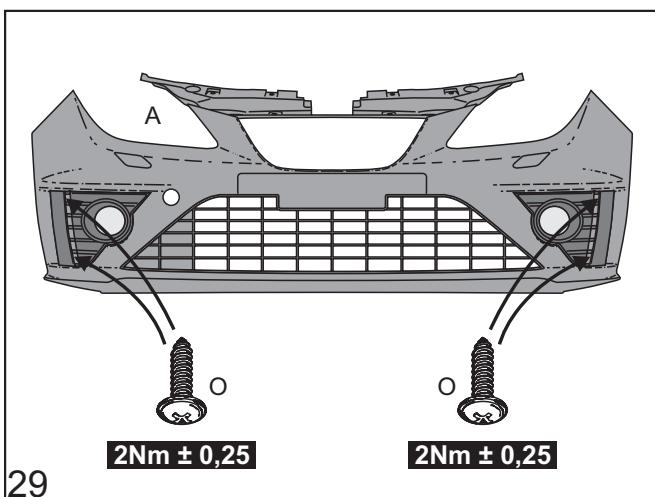
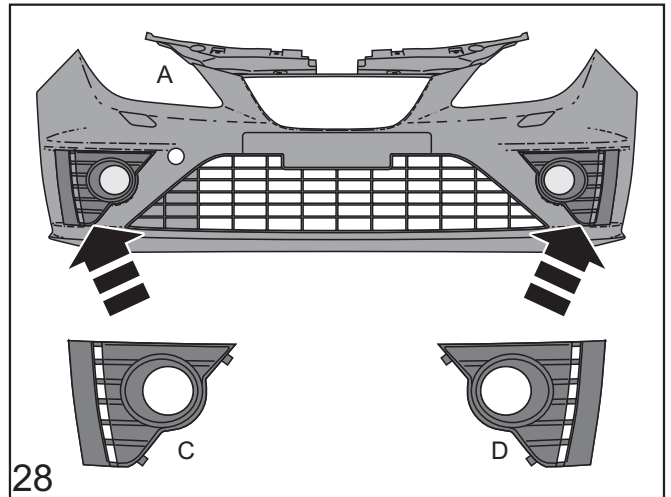
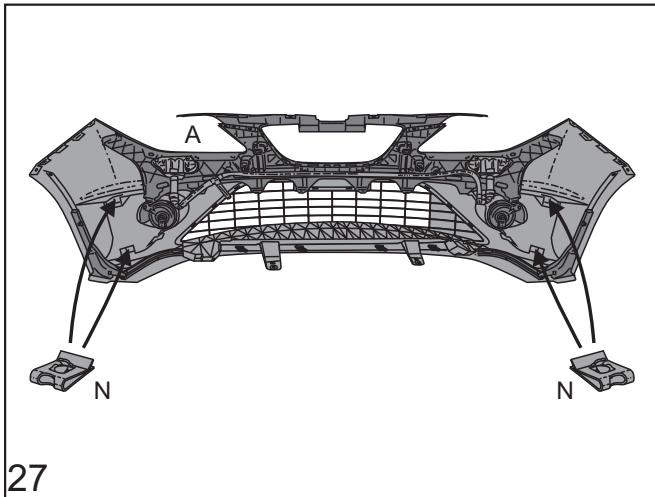
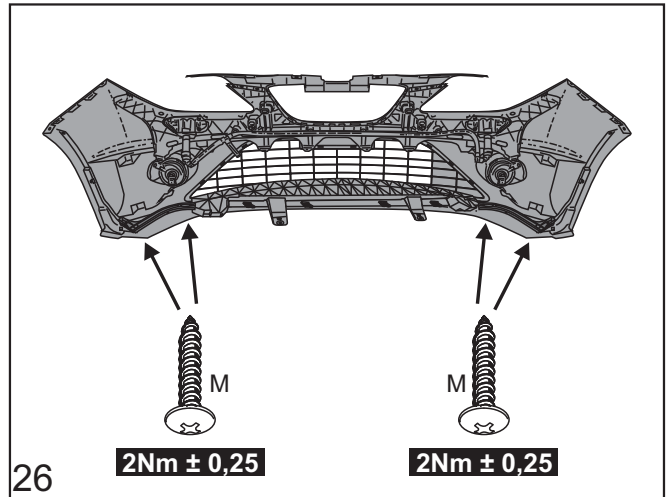
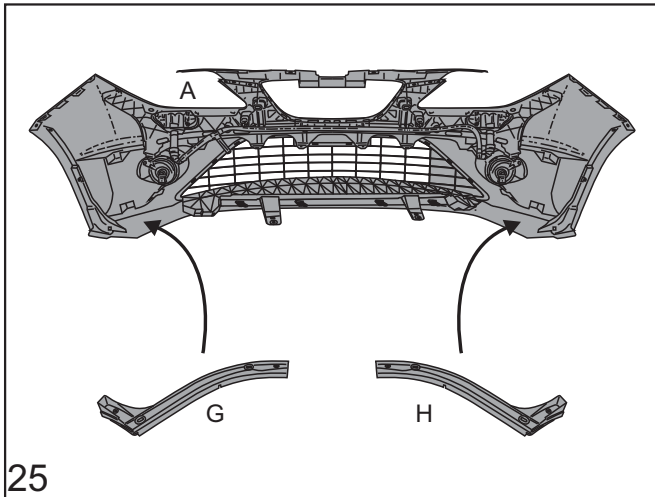
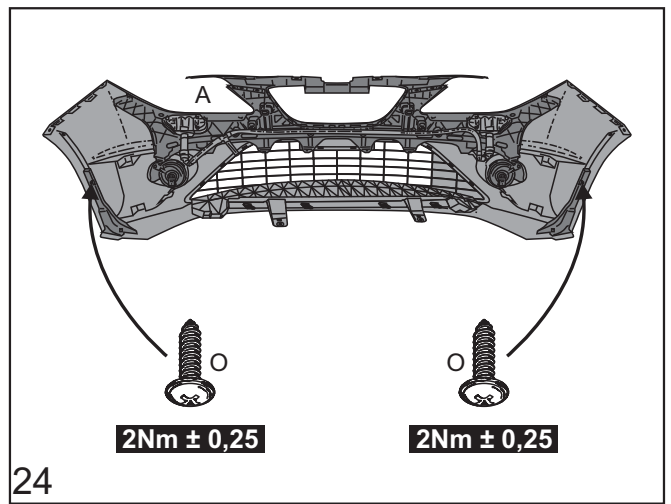
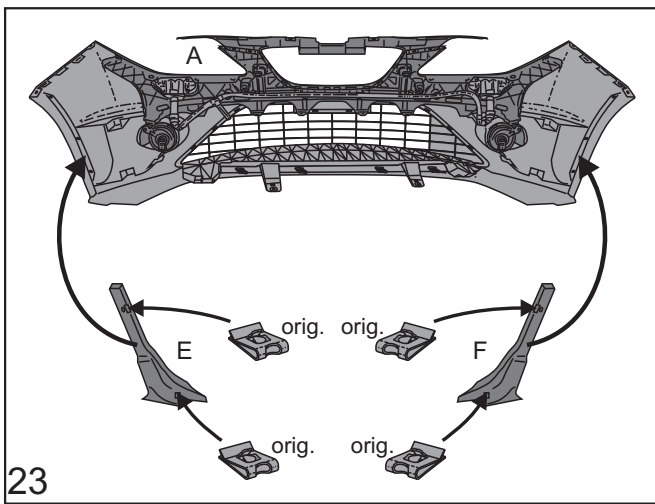

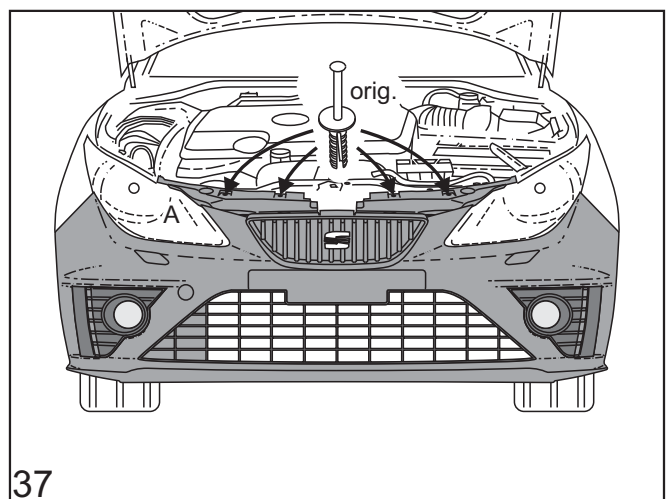
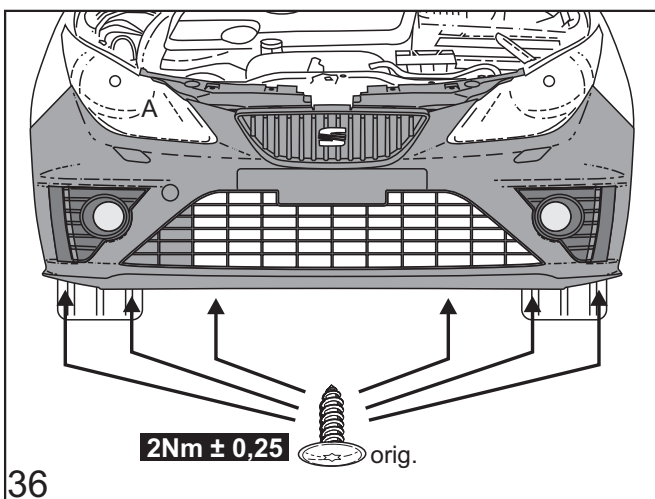
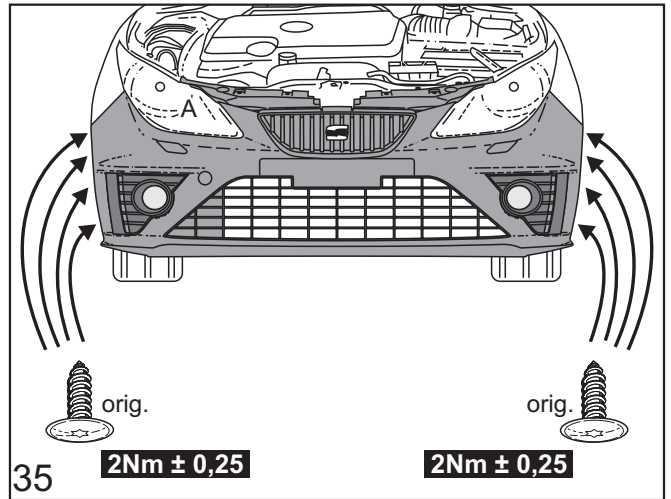
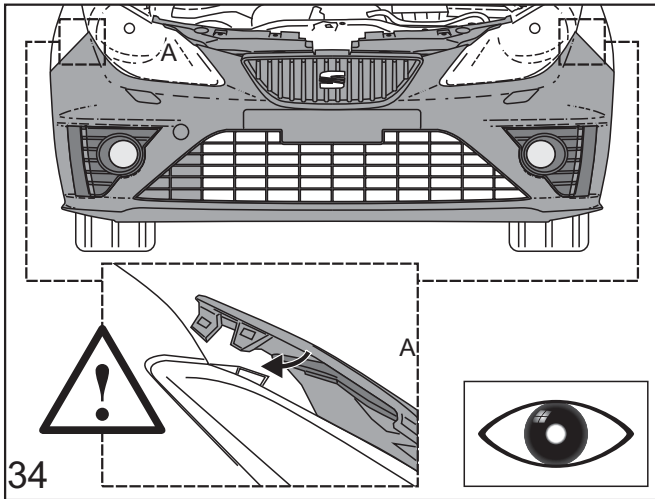
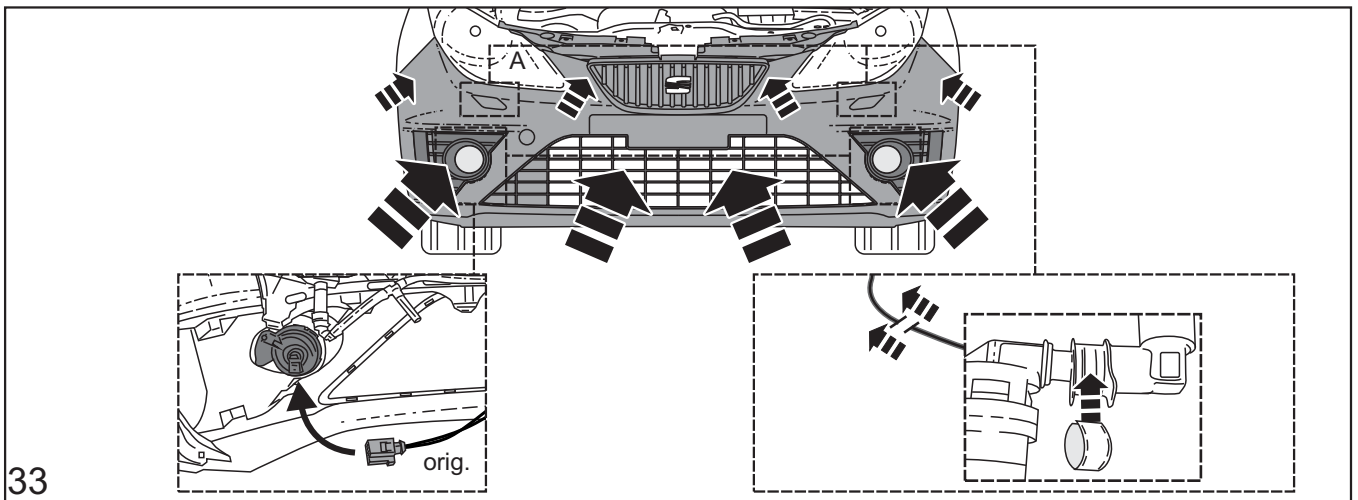
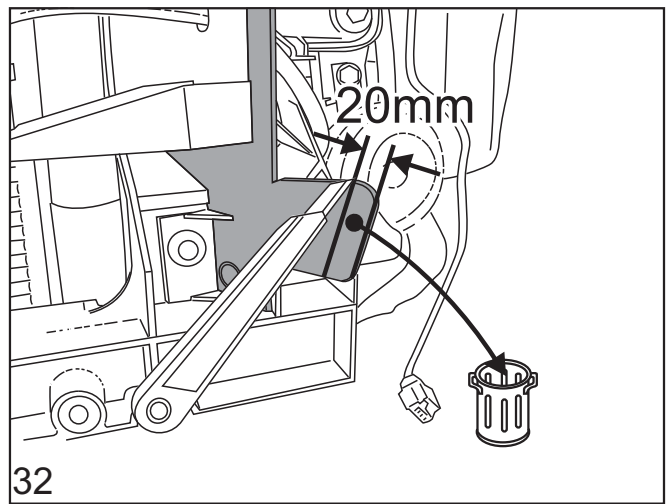
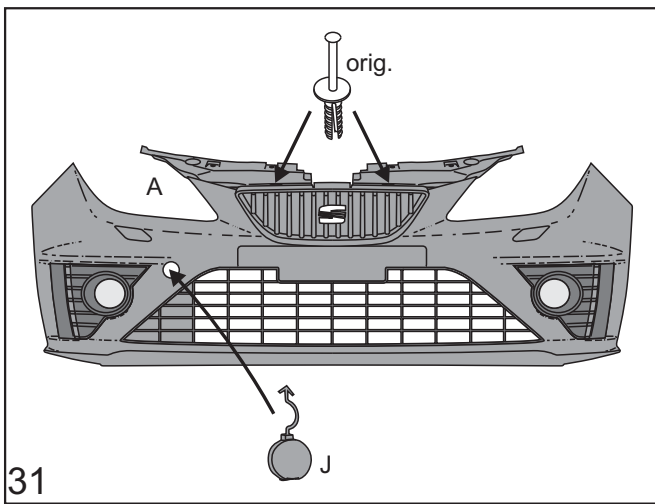

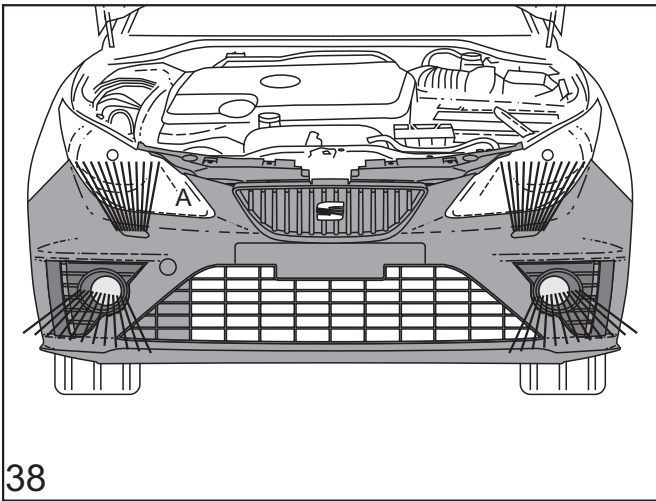

38





### Painting instructions for primed parts



Grind the primed component smoothly (P800-P1000).  
Avoid grinding through the primer.

Check faulty spots, repair them and grind repaired places smoothly (P800-P1000).  
Re-prime ground-through spots using a suitable plastic primer.

Thoroughly clean using a silicone remover.

It is important to ensure adequate component support during the process of painting (distortion risk)!  
Paint buildup and application technique according to the paint manufacturer; the elasticity-imparting additives specified by the paint manufacturer are particularly important.  
The material designation is visible in the interior of the component (>.....<, z.B. >PUR-MF15<).

**No stoving of the paint (maximum 40°C)!**



### Lackieranleitung für grundierete Teile



Grundiertes Bauteil anschleifen (P800-P1000).  
Durchschleifen der Grundierung vermeiden.

Auf Fehlerstellen prüfen und ausbessern sowie Reparaturstellen anschleifen (P800-P1000).  
Durchschleifstellen mit geeigneter Kunststoffgrundierung nachgrundieren.

Gründlich mit Silikonentferner reinigen.

Auf ausreichende Bauteilunterstützung während des Lackierprozesses ist zu achten (Verzugsgefahr)!  
Lackaufbau und Applikationstechnik nach Lackhersteller, auf die vom Lackhersteller vorgegebenen Elastizitätszusätze ist besonders zu achten.  
Die Materialbezeichnung ist auf der Bauteilinnenseite (>.....<, z.B. >PUR-MF15<) ersichtlich.

**Kein Einbrennlackieren (max. 40°C)!**



### Instruction de vernissage pour pièces apprêtées



Poncer le composant apprêté (P800-P1000).  
Eviter une usure de la couche d'apprêt.

Contrôler les emplacements défectueux et retoucher, poncer les emplacements de réparation (P800-P1000).  
Retoucher les emplacements usés par le ponçage avec un apprêt acrylique approprié .

Bien nettoyer avec un produit anti-silicones.

Veiller à bien soutenir le composant pendant le laquage (risque de déformation)!  
Respecter les instructions du fabricant de laque pour la composition et l'application de celle-ci, y compris les additifs plastifiants prescrits.  
Le code de matériau figure sur le côté intérieur du composant (>.....<, p. ex. >PUR-MF15<).

**Pas de laquage avec cuisson (max. 40°C) !**



### Introduzione verniciatura per parti impregnate



Rettificare l'elemento dotato di mano di fondo (P800-P1000).  
Evitare che la mano di fondo sia asportata.

Controllare l'eventuale presenza di punti difettosi e riparare, rettificare i punti di riparazione (P800-P1000).  
Riapplicare un'adeguata mano di fondo in materiale sintetico sui punti in cui la mano di fondo è stata asportata.

Pulire accuratamente con prodotto per eliminare il silicone.

Occorre assicurare un sufficiente supporto dell'elemento durante il processo di verniciatura (pericolo di distorsione)!  
Struttura della vernice e tecnica di applicazione secondo il produttore della vernice, occorre osservare particolarmente gli additivi elastici prescritti dal produttore della vernice.  
La designazione del materiale è riportata sul lato interno dell'elemento (>.....<, p.es. >PUR-MF15<).

**Nessuna verniciatura a fuoco (max. 40°C)!**

**NL****Lakinstructie voor onderdelen in grondverf**

800-1000  
Gegroundverfd component licht schuren (P800-P1000).  
Doorschuren van de grondlaag vermijden.

Op onvolkomenheden controleren en herstellen alsook de gerepareerde plekken licht schuren (P800-P1000).  
Doorgesuurde plekken met een geschikte kunststofgrondlaag nagronden.

Met siliconenverwijderaar grondig reinigen.

Let tijdens het lakken op een toereikende ondersteuning van de componenten (ivm vervorming)!  
Lakproces en applicatietechniek volgens de voorschriften van de lakfabrikant. Bijzondere aandacht is vereist voor de voorgeschreven toevoegingen t.b.v. de elasticiteit  
De materiaalbenaming bevindt zich aan de binnenkant van de component (>.....<, b.v. >PUR-MF15<)

**Niet moffellakken (max. 40°C)!**

**P****Instruções de Pintura para peças com a primeira demão**

800-1000  
Lixar o componente com primeira demão (P800-P1000).  
Evitar o lixamento completo da primeira demão.

Verificar pontos de falha e retocar, assim como lixar os pontos de reparação (P800-P1000).  
Passar uma primeira demão nos pontos que foram lixados por completo com pintura de fundo de material plástico.

Limpar a fundo com removedor de silicone.

Prestar atenção para um suporte suficiente do componente durante o processo de pintura (perigo de estiramento)!  
Estruturação do verniz e técnica de aplicação conforme o fabricante do verniz, observar especialmente os aditivos elásticos prescritos pelo fabricante do verniz.  
A designação do material se encontra no lado interno do componente (>.....<, p.ex. >PUR-MF15<).

**Não é verniz que tenha de sofrer cozimento (máx. 40°C)!**

**E****Instrucciones de Pintura para piezas con la primera capa**

800-1000  
Lijar ligeramente la pieza imprimada (P800-P1000).  
Al lijar, no atravesar la imprimación.

Examinar con respecto a partes defectuosas y retocar, así como lijar ligeramente las partes a reparar (P800-P1000).  
Reimprimir las partes atravesadas con una imprimación sintética adecuada.

Limpiar minuciosamente con quitasilicona.

Tener cuidado de apoyar suficientemente la pieza durante el proceso de pintado (¡peligro de deformación!).  
Estructura de la pintura y técnica de aplicación según el fabricante de pintura. Tener cuidado especial de los aditivos elásticos prescritos por el fabricante de pintura.  
La designación del material puede verse en la parte interior de la pieza (>.....<, p. ej. >PUR-MF15<).

**¡No lacado al fuego (max. 40°C)!**

**CZ****Návod k lakování dílů opatřených základním nátěrem**

800-1000  
Základovaný materiál přibrousit (P800-P1000).  
Vyvarovat se rozbroušení skrz základovou barvu.

Kontrolovat ohledně chybných míst a vyspravit je jakož i přibrousit vyspravovaná místa (P800-P1000).  
Místa rozbroušení dodatečně základovat vhodnou základovou barvou z plastu.

Důkladně očistit odstraňovačem silikonu.

Je třeba dbát na dostatečné podepření dílců během procesu lakování (nebezpečí pokřivení)!  
Struktura laku a technika aplikace podle výrobce laku, obzvlášť je třeba dbát na elastické přísady zadané výrobcem laku.  
Označení materiálu je patrné na vnitřní straně stavebního dílce (>.....<, z.B. >PUR-MF15<).

**Žádné lakování vypalováním (max. 40°C)!**



Οδηγίες βαφής για  
ασταρωμένα μέρη



Λειάνετε το ασταρωμένο τμήμα (P800-P1000).  
Αποφύγετε τη λείανση της πρώτης στρώσης.

Ελέγξτε για πιθανά προβληματικά σημεία, επιδιορθώστε τα και στη συνέχεια λειάνετε τα επιδιορθωμένα σημεία (P800-P1000).  
Τα σημεία λείανσης ασταρώστε τα συμπληρωματικά με κατάλληλο πλαστικό αστάρι.

Καθαρίστε πολύ καλά με μέσο αφαίρεσης της σιλικόνης.

Κατά τη διάρκεια του βερνικώματος (λακαρίσματος) θα πρέπει να φροντίσετε για επαρκή υποστήριξη των αντίστοιχων τμημάτων (κίνδυνος παραμόρφωσης)! Το βερνίκωμα και η τεχνική εφαρμογής σύμφωνα με τον κατασκευαστή του βερνικιού, θα πρέπει να ελέγχεται ιδιαίτερα αναφορικά με τα ελαστικά προσθετικά που αναγράφονται από κείνον.  
Η ονομασία του υλικού εμφανίζεται στο εσωτερικό του αντίστοιχου τμήματος (>.....<, π.χ. >PUR-MF15<).

**Το βερνίκωμα να μη γίνεται σε υψηλές θερμοκρασίες (μέγιστο επιτρεπόμενο όριο θερμοκρασίας 40°C)!**